

C-3/10, Mayapuri Industrial Area,
Phase-II, New Delhi - 110 064
Ph : +91-11-28116079, 65462686 Fax : +91-1128116079
E-mail : info@jrb.in ; Website : www.jrb.in

We and our profile

Presentation of an impressive icon...

Standing tall on the proposals of expertise and knowledge since 1997 **optigear** has immense potential of production of an expansive multiplicity of gears & shafts. Our aspirations of quality, strict integrity and commitment has enabled us to develop a clear cut aim of setting standards in the manufacturing of gears & shafts for LCV's & HCV's for export and aftermarket. Amongst our contemporaries, we are the favorites as we not only accommodate all kinds of special needs and modifications but also work flexibly to comply with extremely severe deadlines.

Our committed group has grown step by step to establish itself firmly on the planks of actuality, ardor, hard work, determination and foresightedness. We neither compromise on quality nor safety thus concreting the trust and credence of our clients.

We have maintained a graceful approach towards our trade thus offering a steadfast word of honor, time deliverance, and quality, the synonym of our brand name. Our status of being a 'Numero Uno' get further augmented due to latest testing equipments that support our claim to be one of the biggest gear manufacturers in northern India.

Machines

Our technology speaks loud...

Our company upholds the vision of customer-care coupled with the best quality of products that we produce. Our ambitious vision gets fulfilled at our manufacturing plant that is outfitted with the most modern technology, trained management, qualified engineers, technicians and expert workers.

We are the proud possessors of following machineries that are of reputed brands :-

Machinery		Testing
Cnc Turning	Tooth Swaging	Lead & Profile
Cnc Milling	Internal Grinder	P.C.D. Runout Tester
Gear Hobbing	Cylindrical Grinder	Roll Tester
Gear Shaper	Drilling	Hardness Tester
Gear Shaving	Champhering	
Broaching	Threading	
Tooth Rounding		

Our R&D department works consistently to ensure generation of consistently superior products along with an efficient quality department that conducts stringent and constant inspections right from raw material to refined products.

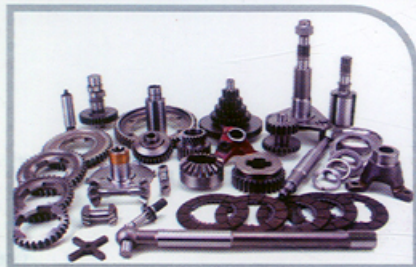

Products, Services and Quality

Your profit our promise...

We excel in the manufacturing gears and shafts of HCV's and LCV's. In addition to these there is also a wide array of Gears & Shafts for Industrial Gear Boxes, Combines, Earthmovers etc. Our well-fabricated gears & shafts are also exported to Germany, Indonesia, Srilanka, Egypt etc.

At JRB ENGINEERING WORKS, the work ethics are multi-dimensional. While cooperation is the ultimate key word, other principals like teamwork, awareness and dexterity also constitute its paradigms.

Our brand name **optigear** is not merely a peripheral image of a product but transmits the support and sustenance of our deft professionals who are part of our product's manufacturing right from the first step to the last one.

In sync with Culture- Innovation-Hard work Instituting milestones...

JRB ENGINEERING WORKS is a dynamic organization that has supreme capabilities of successfully transforming every need and requirement of our customer's pleasant deliverance. We never rest over our achieved laurels and rather continually work with amazing zeal to create newest milestone with the quality of our every product. Service and flexibility being paramount for us, we pledge the nonstop development of our high standards and quality norms incessantly.

We stand strong for:

- Uppermost quality standards
- Wide-ranging market – oriented product range
- Regular interface with our customers

We thus remain unswervingly committed to upgrade our technology and build up utmost customer-contentment.



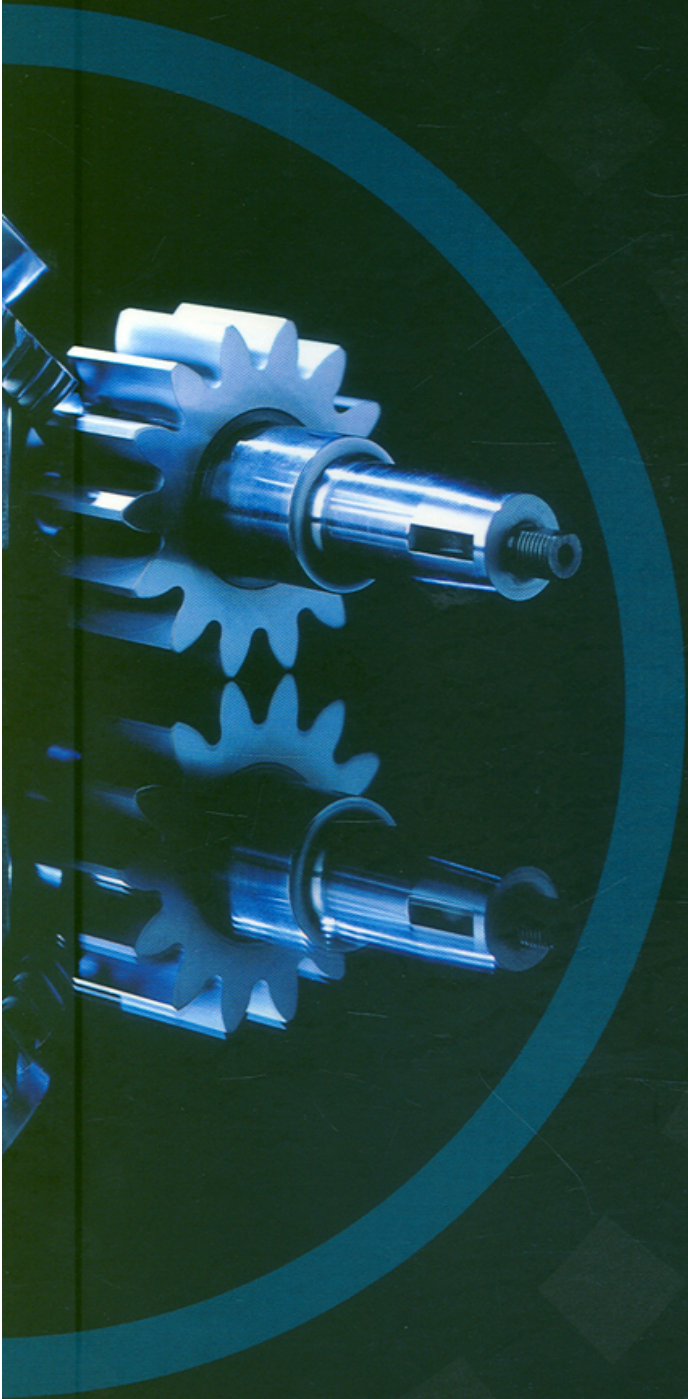

JRB ENGINEERING WORKS



TRANSMISSION GEARS

INDUSTRIAL GEARBOXES

Shaft Mounted Speed Reducer

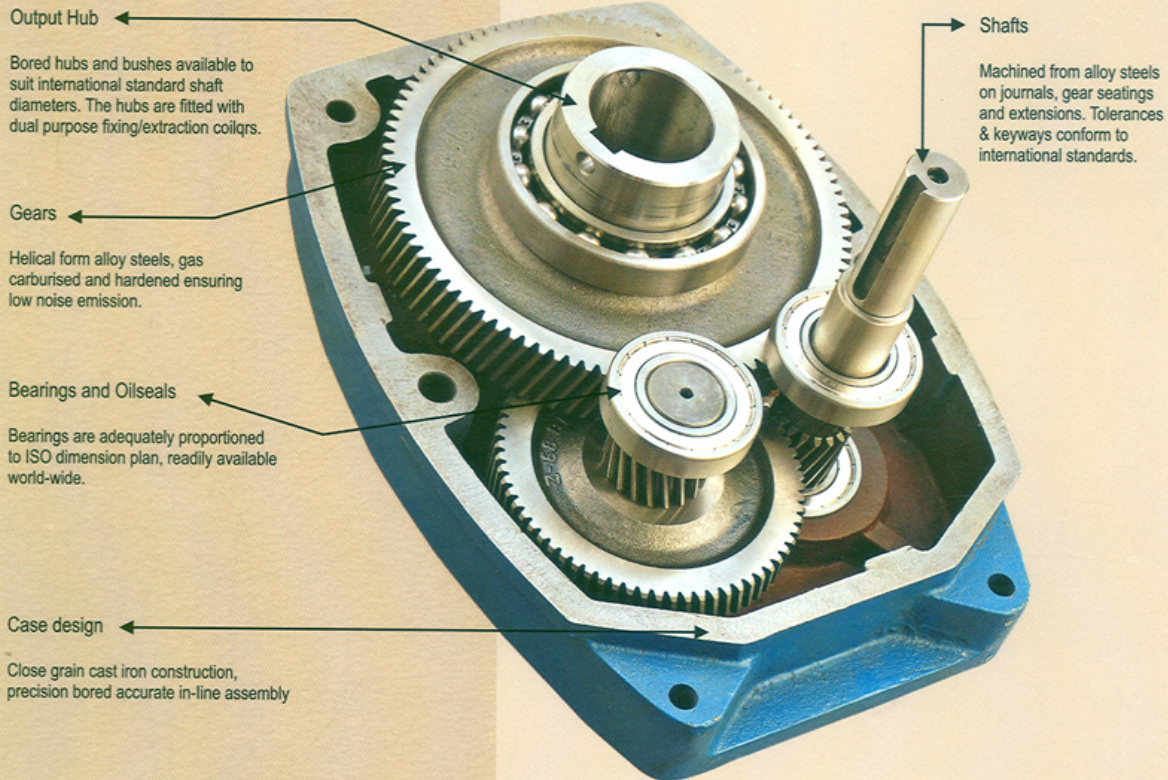

The  Shaft Mounted Speed Reducer provides a very convenient method of reducing speed, since it is mounted directly on the driven shaft instead of requiring foundations of its own. It eliminates the use of one and sometimes two flexible couplings and external belt take-up arrangements.

A torque-arm anchors the Reducer and provides quick easy adjustment of the V-Belts by means of its turnbuckle. The Optigear Speed Reducer is manufactured in eight gear case sizes, designated by the letters B to H. The eight sizes may have anyone of three nominal gear ratios 5: 1, 13: 1 and 20: 1.

A very wide choice of final driven speed can be determined by the use of an appropriate input V -Belt drive. The units are normally oil lubricated, but they are equally suitable for "lubricated for life" greases.

Shaft Mounted Speed Reducer

SELECTION PROCEDURE

- (a) Service Factor - From Table 1 select the service factor applicable to the drive.
- (b) Design Power - Multiply the absorbed power (or motor power if absorbed power not known) by the service factor chosen in step (a).
Note: Ensure that design power exceeds motor rated power.
- (c) Peak Load - Divide any peak load by two.
- (d) Unit Selection - Using the greater value of steps (b) and (c) refer to the Power Rating Tables and select the correct size of unit. The choice of single or double reduction gearbox will be determined by the output speed required. The normal operating speeds for each of the gearboxes may be observed in the Power Rating Tables. For other speeds CONSULT OPTIGEAR.
Note: 5.1 Units require special selection when fitted with backstops CONSULT OPTIGEAR
Selection of Associated Drive for 1440 rev/min Electric Motors
- (e) Output Speed - Refer to the Drive Selection Tables and under the appropriate gearbox size and ratio read down the column headed 'Output Speed' until an output speed equal or near to that required is found

TABLE - SERVICE FACTORS

Types of Driven Machine	Operational Hours Per Day		
	Under 10	10 to 16	16 and over
Uniform Agitators and Mixers-liquid or semi-liquid Blowers -centrifugal Bottling Machines Conveyors and Elevators - uniformly loaded Cookers Laundry Washing Machines -non-reversing Line Shafts Pumps - centrifugal and gear Wire Drawing Machines	1.0	1.12	1.25
Moderate Shock Agitators and Mixers - variable density Conveyors - not uniformly loaded Cranes, travel motion and hoisting Drawbench Feeders - pulsating load Hoists Kilns Laundry Tumblers Lifts Piston Pumps - with 3 or more cylinders Pulp and Paper Making Machinery Rubber Mixer. and Calenders Rotary Screens Textile Machinery	1.0	1.12	1.25
Heavy Shock Brick Presses Briquetting Machines Conveyors - reciprocating and shaker Crushers Feeders - reciprocating Hammer Mills Piston Pumps - 1 or 2 cylinders Rubber Masticators Vibrating Machines	1.6	1.8	2.0

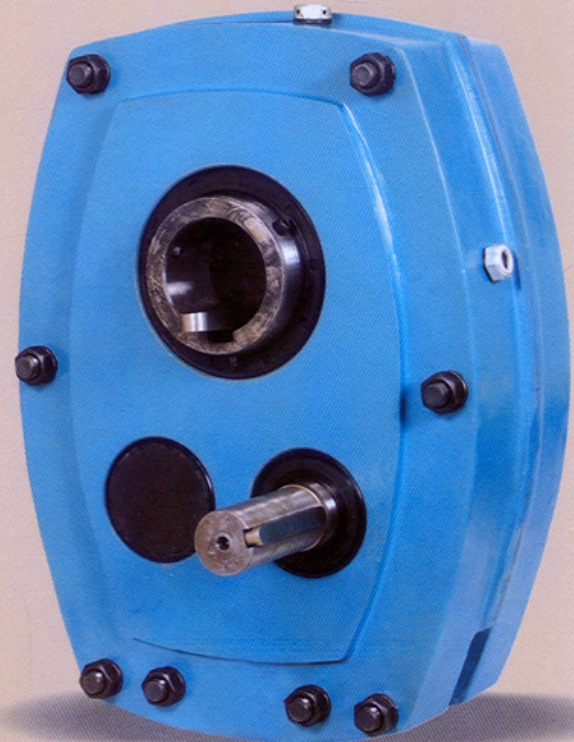

- (f) Pulley Diameters - Read across: from the chosen output speed to obtain both driving and driven pulley pitch diameters and the appropriate number of belts.
- (g) Centre Distance - Belt length and centre distance can be found by referring to pages 2 & 4 of Wedge Belt catalogue.
Selection of Associated Drive for Driving Speeds other than 1440 rev/min
- (h) Design Power - Obtain from the Power Rating Tables the rated power of the gearbox at the required output speed and use it as the design power for the drive
- (i) Gearbox Input Shaft Speed - Multiply the gearbox output speed by the exact gear ratio to obtain the gearbox input shaft speed
- (j) Selection of V-Drive - Combination of pulleys can be chosen. It is advisable not to select a gearbox pulley smaller than that shown in the drive tables for the approximate speed required

Shaft Mounted Speed Reducer

TABLE - POWER RATINGS (kw)5:1 UNITS

Output Rev/Min	BO5	CO5	DO5	EO5	FO5	GO5	HO5	JO5
50	1.29	1.84	3.18	5.11	7.01	12.7	17.8	31.5
60	1.40	2.05	3.51	5.58	7.73	13.6	19.3	37.0
70	1.51	2.26	3.82	6.03	8.43	14.6	20.7	42.2
80	1.62	2.46	4.13	6.47	9.11	15.5	22.2	47.7
90	1.73	2.66	4.43	6.89	9.76	16.4	23.6	53.3
100	1.84	2.85	4.73	7.30	10.4	17.3	25.0	59.2
110	1.96	3.03	5.01	7.70	11.0	18.3	26.4	64.0
120	2.07	3.20	5.29	8.09	11.6	19.2	27.8	69.0
130	2.18	3.37	5.56	8.46	12.1	20.2	29.1	73.0
140	2.30	3.54	5.82	8.82	12.7	21.1	30.5	75.4
150	2.41	3.70	6.08	9.17	13.2	22.0	31.8	78.0
160	2.53	3.85	6.33	9.52	13.7	22.9	33.1	81.0
170	2.64	4.00	6.57	9.85	14.2	23.9	34.4	84.0
180	2.76	4.14	6.81	10.2	14.6	24.8	35.7	86.0
190	2.88	4.28	7.03	10.5	15.1	25.7	36.9	89.0
200	2.99	4.41	7.26	10.8	15.5	26.6	38.1	92.0
210	3.11	4.54	7.47	11.1	15.9	27.4	39.3	94.0
220	3.23	4.67	7.68	11.4	16.3	28.3	40.5	97.0
230	3.35	4.79	7.88	11.7	16.7	29.2	41.6	99.0
240	3.46	4.91	8.06	11.9	17.1	30.0	42.7	102.0
250	3.54	5.02	8.24	12.2	17.4	30.9	43.7	104.0
260	3.70	5.13	8.41	12.5	17.7	31.7	44.8	106.0
270	3.82	5.24	8.58	12.7	18.0	32.5	45.8	108.0
280	3.93	5.35	8.75	13.0	18.4	33.2	46.7	110.0
290	4.05	5.45	8.91	13.2	18.6	34.0	47.7	111.0
300	4.17	5.55	9.07	13.5	18.9	34.7	48.5	113.0
310	4.28	5.65	9.23	13.7	19.2	35.5	49.4	117.0
320	4.40	5.75	9.39	14.0	19.4	36.2	50.2	118.0
330	4.51	5.85	9.55	14.2	19.7	36.8	51.0	119.0
340	4.63	5.94	9.71	14.5	19.8	37.5	51.7	119.5
350	4.74	6.04	9.87	14.7	20.1	38.1	52.3	120.0
360	4.85	6.13	10.0	14.9	20.4	38.7	53.0	122.0
370	4.97	6.22	10.2	15.2	20.6	39.3	53.6	123.0
380	5.08	6.32	10.4	15.4	20.8	39.8	54.1	124.0
390	5.19	6.41	10.5	15.7	20.9	40.3	54.6	125.0
400	5.30	6.50	10.7	15.9	21.1	40.8	55.0	127.8
Torque at 50rev/min Nm	246	351	607	976	1339	2426	3400.0	6017.0

The dotted line shows the speed limitation for 5:1 unit with backstops: for slow speed operation - CONSULT Optigear

POWER RATINGS (kw) 13:1 AND 20:1 UNITS

Output Rev/Min	B13	C13	D13	E13	F13	G13	H13	J13
	B20	C20	D20	E20	F20	G20	H20	J20
10	0.27	0.45	0.76	1.16	1.82	2.88	4.52	7.26
12	0.33	0.53	0.89	1.38	2.16	3.43	5.47	8.49
14	0.38	0.61	1.03	1.60	2.51	3.98	6.30	9.95
16	0.43	0.70	1.18	1.82	2.86	4.53	7.11	11.2
18	0.48	0.79	1.31	2.04	3.19	5.07	8.01	12.6
20	0.54	0.87	1.46	2.25	3.54	5.62	8.79	14.0
22	0.58	0.95	1.60	2.47	3.87	6.14	9.64	15.2
24	0.63	1.03	1.73	2.68	4.21	6.68	10.5	16.6
26	0.68	1.11	1.87	2.90	4.55	7.20	11.2	17.9
28	0.74	1.20	2.02	3.11	4.88	7.73	12.1	19.1
30	0.79	1.28	2.15	3.32	5.21	8.25	12.9	20.4
32	0.84	1.37	2.29	3.53	5.54	8.78	13.8	21.5
34	0.89	1.45	2.43	3.74	5.87	9.29	14.5	22.8
36	0.95	1.53	2.56	3.95	6.20	9.81	15.3	23.9
38	1.00	1.62	2.70	4.15	6.52	10.3	16.1	25.1
40	1.05	1.70	2.84	4.36	6.85	10.8	16.9	26.3
42	1.09	1.79	2.96	4.56	7.17	11.3	17.6	27.4
44	1.14	1.86	3.10	4.77	7.49	11.9	18.5	28.6
46	1.19	1.94	3.22	4.97	7.81	12.4	19.2	29.6
48	1.24	2.02	3.36	5.18	8.11	12.8	20.0	30.8
50	1.29	2.09	3.50	5.38	8.39	13.3	20.7	31.8
52	1.34	2.16	3.63	5.58	8.68	13.9	21.3	33.0
54	1.39	2.24	3.76	5.77	8.97	14.4	22.1	34.0
56	1.44	2.31	3.90	5.97	9.26	14.8	22.8	35.2
58	1.49	2.38	4.02	6.17	9.54	15.3	23.5	36.2
60	1.54	2.48	4.15	6.37	9.82	15.9	24.3	37.3
62	1.60	2.52	4.28	6.57	10.1	16.3	25.0	38.3
64	1.64	2.59	4.42	6.77	10.2	16.8	25.7	39.5
66	1.69	2.67	4.55	6.97	10.7	17.2	26.5	40.5
68	1.73	2.74	4.67	7.16	10.9	17.7	27.1	41.6
70	1.79	2.81	4.80	7.36	11.2	18.3	27.8	42.6
72	1.83	2.89	4.94	7.56	11.4	18.7	28.5	43.8
74	1.87	2.95	5.06	7.75	11.8	19.2	29.1	44.8
76	1.92	3.02	5.19	7.95	12.1	19.6	29.7	45.9
78	1.96	3.10	5.33	8.14	12.3	20.2	30.5	46.9
80	2.02	3.17	5.43	8.34	12.6	20.6	3.12	47.8
85	2.13	3.35	5.74	8.81	13.3	21.8	32.9	50.3
90	2.25	3.54	6.06	9.29	13.9	23.0	34.4	52.7
95	2.37	3.74	6.37	9.77	14.7	24.2	36.1	55.2
100	2.48	3.92	6.68	10.2	15.4	25.3	37.7	57.6
105	2.59	4.12	6.99	10.7	16.2			
110	2.71	4.32	7.30	11.1	16.9			
115	2.82	4.50	7.59					
120	3.00	4.81	8.01					
140	3.48	5.30	9.35					
160	3.89	5.91						
180	4.35	6.60						
Torque at 10 rev/min Nm	260	431	722	1103	1733	2751	4316	6930

The dotted line shows the limit of recommended output speed for reducers with 20: 1 ratio. For higher speeds use a 13: 1 or 5: 1 reducer.

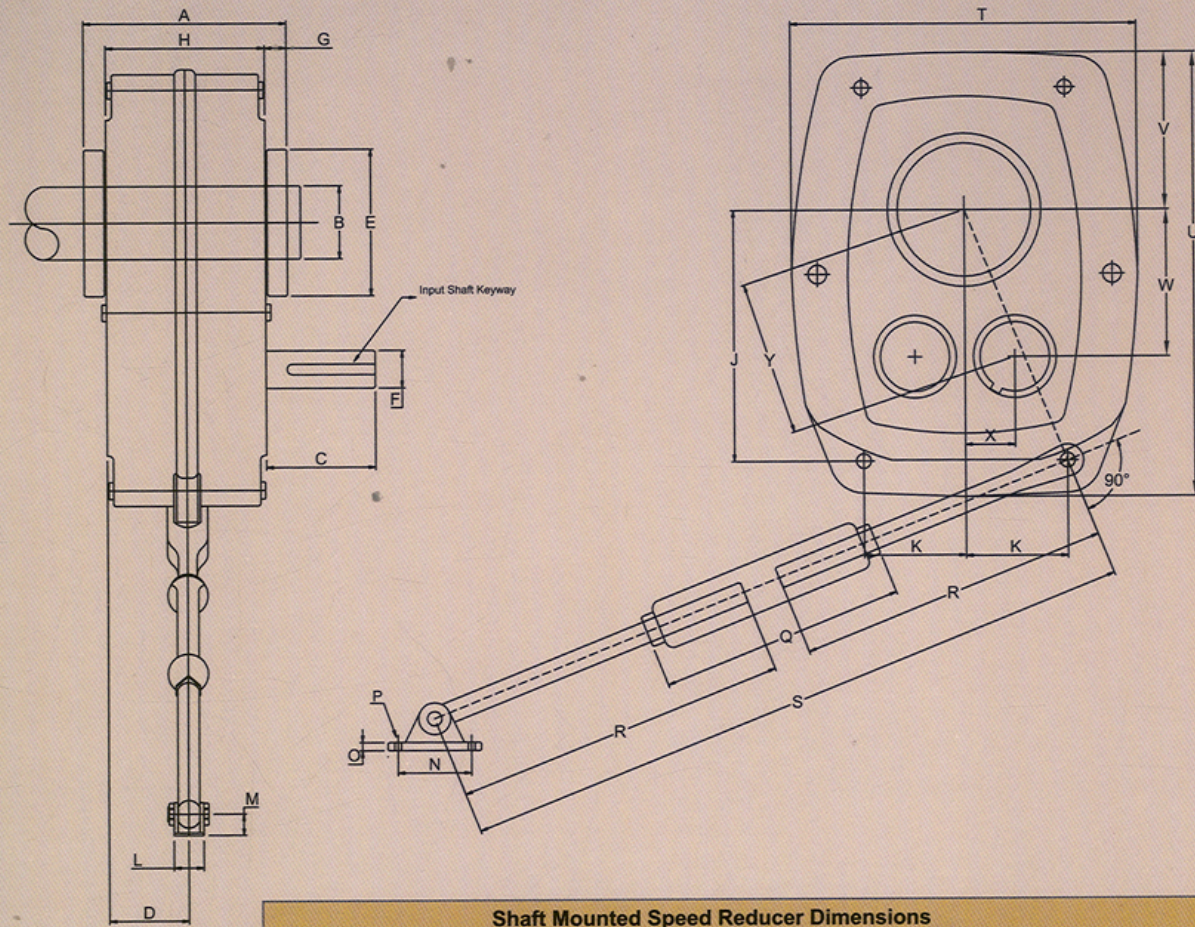

Shaft Mounted Speed Reducer Dimensions								
Dimension	B	C	D	E	F	G	H	J
A	143	142	152	160	192	212	242	257
B	30	40	55	55	65	75	85	100
C	63	72	76	87	113	108	116	138
D	52	65	59	65	75	86	95	98.5
E	80	90	100	110	131	140	170	200
F	19	22	25	28	32	42	48	58
G	15	17	17	20	20	20	26	30
H	104	108	118	130	150	172	190	197
J	131	156	188	219	255	255	330	470
K	55	59	76	90	100	110	137	140
L	16	16	16	16	26	26	26	26
M	25	25	25	25	65	65	65	65
N	75	75	75	75	125	125	125	125
O	5	5	5	5	20	20	20	20
P	13	13	13	13	16	16	16	16
Q	204	204	204	204	255	255	255	285
R	385	385	385	385	375	375	375	375
S Max	920	920	920	920	900	900	900	900
S Min	770	770	770	770	750	750	750	750
T	186	218	258	278	330	365	434	600
U	226	270	328	376	440	468	550	730
V	81	96	117	129	156	162	195	260
W	75	90	110	125	141	156	189	255
X	25	31	37	43	50	56	62	75
Y	79	95	116	133	150	166	200	265.77
Keyway	6x3.5x50	6x3.5x56	8x4x67	8x4x73.50	10x5x85	12x5x90	14x5.5x100	16x6x110
Weight (Kg.)	17	23	34	45	72	97	146	270

All dimensions are in mm. Keyways are British Standard metric.

Output Hub & Key Size

MODEL	Output shaft Bore Dia	Key Size (In mm.)	Input Shaft Pulley Dia	Key Size (In mm.)
B	30	8x8x125	19 mm	7x6x50
	40	8x8x125	19 mm	7x6x50
C	40	16x10x140	22 mm	8x7x57
	50	16x10x140	22 mm	8x7x57
D	40	16x10x145	25 mm	8x8x57
	50	16x10x145	25 mm	8x8x57
	55	16x10x145	25 mm	8x8x57
E	50	16x10x160	28 mm	8x7x70
	55	16x10x160	28 mm	8x7x70
	60	16x10x160	28 mm	8x7x70
F	55	18x11x180	32 mm	10x10x85
	60	18x11x180	32 mm	10x10x85
	65	18x11x180	32 mm	10x10x85
	70	18x11x180	32 mm	10x10x85
G	70	20x12x200	42 mm	12x10x90
	75	20x12x200	42 mm	12x10x90
	80	20x12x200	42 mm	12x10x90
G Modified	85	22x14x200	42 mm	12x10x90
H	80	22x14x230	48 mm	14x12x100
	85	22x14x230	48 mm	14x12x100
	90	22x14x230	48 mm	14x12x100
J	100	28x16x250	58 mm	16x11x110
	105	28x16x250	58 mm	16x11x110

STANDARD KEYWAYS

Keyways for output hubs and bushes are machined in accordance with B.S. 4235/IS. 2048 for metric shafts and B.S.. 46 for inch shafts.

Keys are supplied with reduction bushes, but not where the output hubs directly fit the shaft.

Reduction bushes maybe supplied with two separate keys for hub and shaft or a single stepped key, depending on the bush wall thickness.

The shaft keyway should be machined to suit the standard key size shown below regardless of the hub bore diameter

OPTIONAL EXTRAS

Backstops : A backstop may be incorporated on applications where it is necessary to prevent reversal of rotation. It is quickly installed within the Reducer by simply removing a cover plate.

STANDARD HUB KEYWAYS

Keyways for the standard Output Hubs & Bushes are machined in accordance with BS 4235 for metric shafts and BS 46 for "inch" shafts.

Keys are supplied with reduction bushes, but not where the output hub directly fits the shafts.

Reduction bushes may be supplied with two separate keys for hub and shaft or a single stepped key, depending on the bush wall thickness.

The shaft keyway should be machined to suit the standard key size shown below, regardless of the hub bore diameter.

MODEL	RATING AT 40rpm 13(KW) 20:1 RATIO	RATING AT 200rpm (KW) 5:1 RATIO	HEIGHT (mm)	WIDTH (mm)	DEPTH (mm)	STANDARD HUB BORE (mm)	ALTERNATIVE HUB BORE (mm)	APPROX. MASS KG. 20:1	320 No. Oil Required Oil Limit
B	1.05	2.99	226	186	134	30	40	17.00kg.	1.5 to 2 ltr
C	1.70	4.41	270	218	142	40	50	23.00kg.	1.5 to 2 ltr
D	2.84	7.26	328	258	152	50	55	34.00kg.	2.5 to 3 ltr
E	4.36	10.80	377	278	170	55	60	45.00kg.	3.5 to 4 ltr
F	6.85	15.50	414	317	189	65	70	72.00kg.	5 to 5.5 ltr
G	10.80	26.60	468	365	212	75	80	97.00kg.	7.5 to 8 ltr
H	16.90	38.10	550	434	242	85	90	146.00kg.	10.5 to 11 ltr
J	26.30	92.00	700	542	257	100	105	270.00kg.	21 to 22 ltr

MODEL	CONVEYORS BELT SIXES OF SHAFT MOUNTED GEAR BOX
D	18" belt width x length 20ft, 30ft, 40ft, 50ft
E	24" belt width x length 30ft, 40ft, 50ft, 60ft
F	30" belt width x length 30ft, 40ft, 50ft, 60ft
G	36" belt width x length 30ft, 40ft, 50ft, 60ft, 70ft, 80ft, 100ft
H	48" belt width x length 40ft, 60ft, 70ft, 80ft, 100ft
J	60" belt width x length 40ft, 60ft, 80ft, 100ft, 150ft

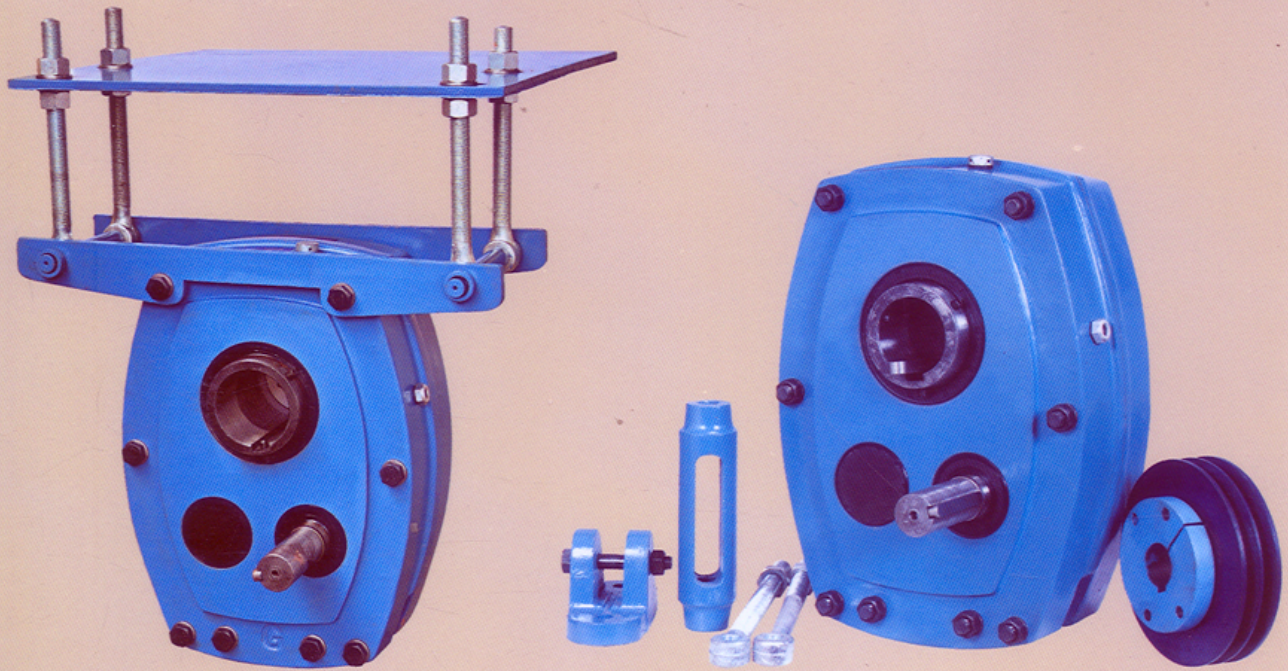

Gearbox with Stand

Other Range of Gearboxes

Round Shaft Mounted Speed Reducer

MODEL	Output Shaft ID	Output Shaft Key Size	Output Shaft Length	Input Shaft Pullt DIA	Input Shaft Key Size
OP 45 - 55	45	16 x 10 x 145	162	28	8 x 7 x 50
	50	16 x 10 x 145	162	28	8 x 7 x 50
	55	16 x 10 x 145	162	28	8 x 7 x 50
OP 60 - 70	60	20 x 12 x 170	200	38	10 x 10 x 70
	70	20 x 12 x 170	200	38	10 x 10 x 70

All above sizes in mm

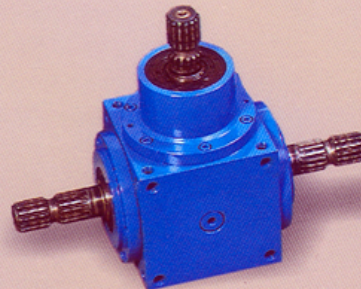
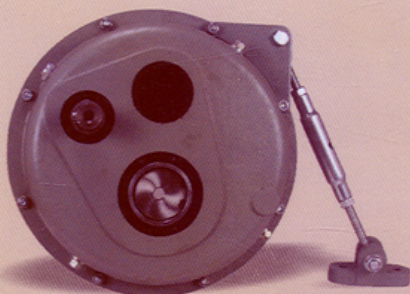

Right Angle Bevel Gearbox



TRANSMISSION GEARS

JRB ENGINEERING WORKS

C-3/10, Mayapuri Industrial Area,

Phase-II, New Delhi - 110064

Tele : +91-11-28116079, 45626079

Fax : +91-11-28116079

Email : info@jrb.in

Website : www.jrb.in